

Transaxle and PMSM Hub Motor for Urban mobility

Rotontek Low-Noise Electric drive Axle
All gear made by forged alloy steel Fine tooth grinding
Making your driving quieter and more comfortable

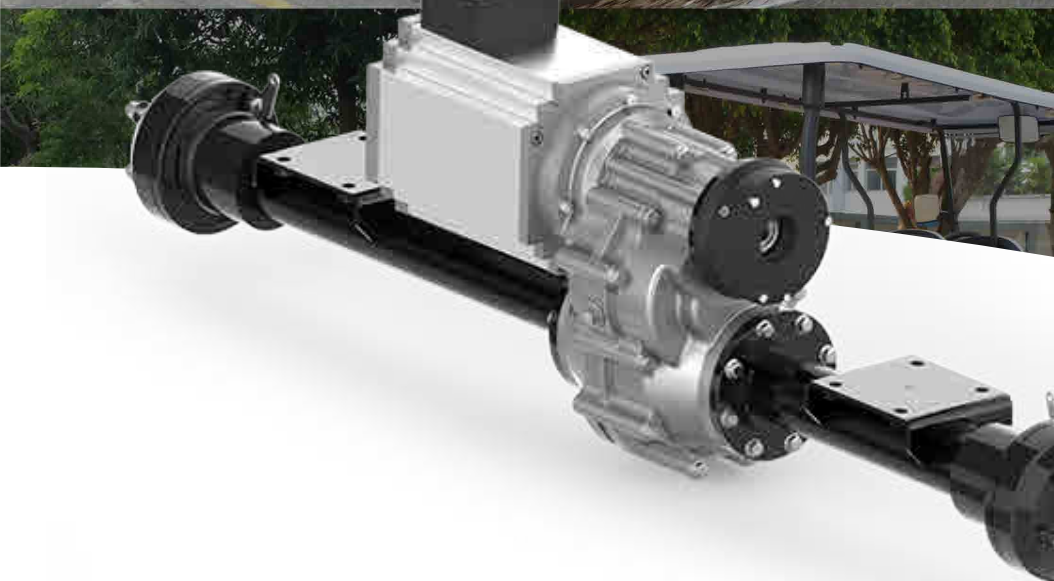

P1

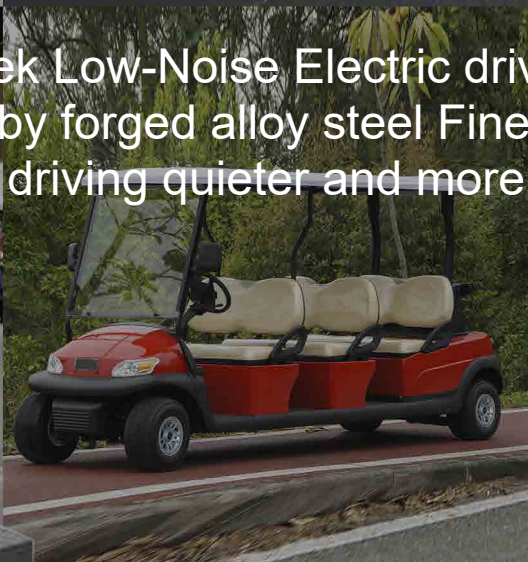

Youtube



Quietness is a result due to quality material precision process

Alloy steel gears with level 6 precision



Brushless Motor Independent R&D and production



Motor control Independent R&D and production



The noise of LD62 series transaxle 54dB, but the compared to more than 68dB. LD62 High transmission efficiency and stable operation. Integrated brake in one, small and beautiful, easy to install.



LD62-823 3000/4000/5000

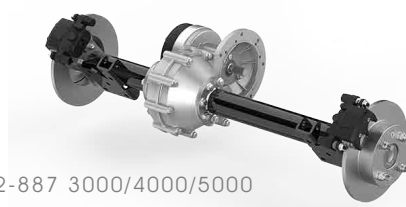

LD62-887 3000/4000/5000

Model	Rated voltage	Rated power	Transmission ratio	Motor efficiency	Motor diameter	Electromagnetic brake	Noise
LD62-823 LD62-887	DC 48-72V	3000W 4000W 5000W	1: 10.42 1: 12.79 1: 16	92%	Ø176	25Nm 46Nm	≤54dB

11KW-20KW Permanent Magnet Transaxle

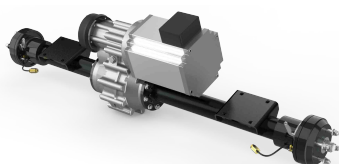

The layout is compact, the overall rigidity is strong, and the gears are made of special materials and advanced technology; they have higher precision and strength, lower noise, wear-resistant tooth surfaces, and longer life. The transmission efficiency of the gear is higher and powerful. Has a strong climbing ability. It is safer and more reliable to configure hydraulic drum brakes. Applicable occasions: Suitable for golf carts, patrol cars, sightseeing cars and other electric vehicles.

Model	Rated voltage	Rated power	Transmission ratio	No-load speed	Rated torque	Motor efficiency	Motor profile	Electromagnetic brake	Noise
ND72-1-22	DC 48V~72V AC 48V~72V	11KW	1:22	272RPM	539Nm	85%	220x220	46Nm	≤72dB

Low-noise AC/PMSM motor drum brake/disc brake drive axle ND520 series



Model	Rated voltage	Rated power	Gearbox reduction ratio	Rated speed	Sensor Type	Noise	Maximum load weight	Shaft length
ND520 drum brake	DC 48V~72V AC 48V~72V	3KW/4KW 5KW/7.5KW	1:12.79/1:16	3000RPM	Pulse encoder Electromagnetic encoder Rotary transformer	≤60	1000KG	Customizable on demand

Model	Rated voltage	Rated power	Gearbox reduction ratio	Rated speed	Sensor Type	Noise	Maximum load weight	Shaft length
ND520 disc brake	DC 48V~72V AC 48V~72V	3KW/4KW 5KW/7.5KW	1:12.79/1:16	3000RPM	Pulse encoder Electromagnetic encoder Rotary transformer	≤60	1000KG	Customizable on demand

3000W 9-inch PMSM electric hub motor



Model	Motor type	Motor voltage	Rated power	Rated speed	IP Rating	Class	Noise
LQM98A	PMSM	DC48V 72V	3000W	460	IP67	F	≤60

Accessories

SHOCK ABSORBER	LEAF SPRING	U BOLT	SHACKLE PLATE	SHOULDER BOLT	SPACER	FLANGED BUSHING

ID600 Drive Controller Permanent magnet motor and AC motor can be controlled



Model	Rated voltage	Continuous current	Peak current	Motor sensor type	Size
ID600-2300 ID600-2500 ID600-4300 ID600-4500 ID600-6500	24V 36-48V	100A 175A	200A 350A	Hall A/B incremental encoder SIN/COS communication	260x260x106mm

Control system and drive system solutions

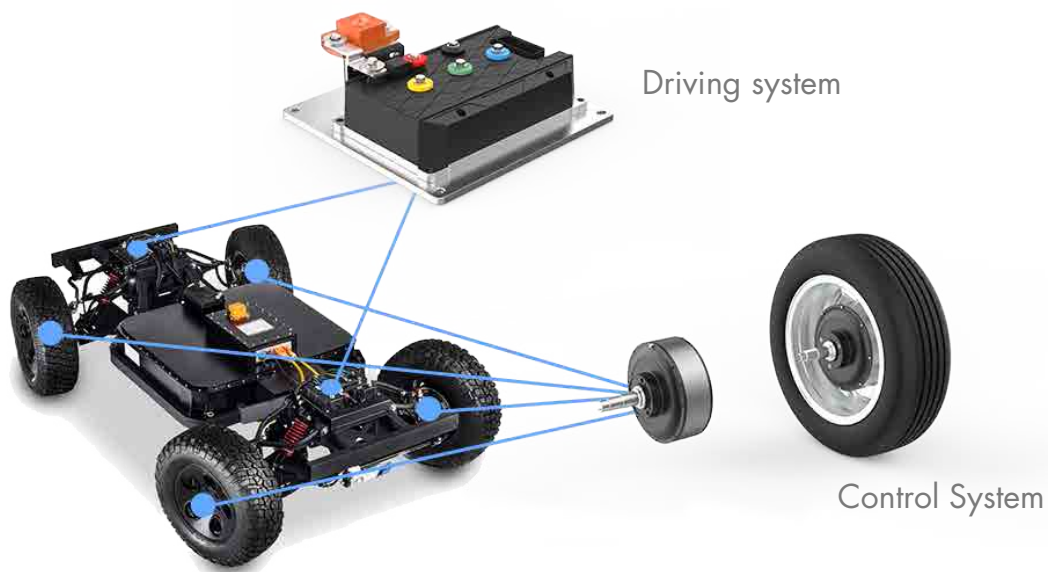

Control system and drive system solutions

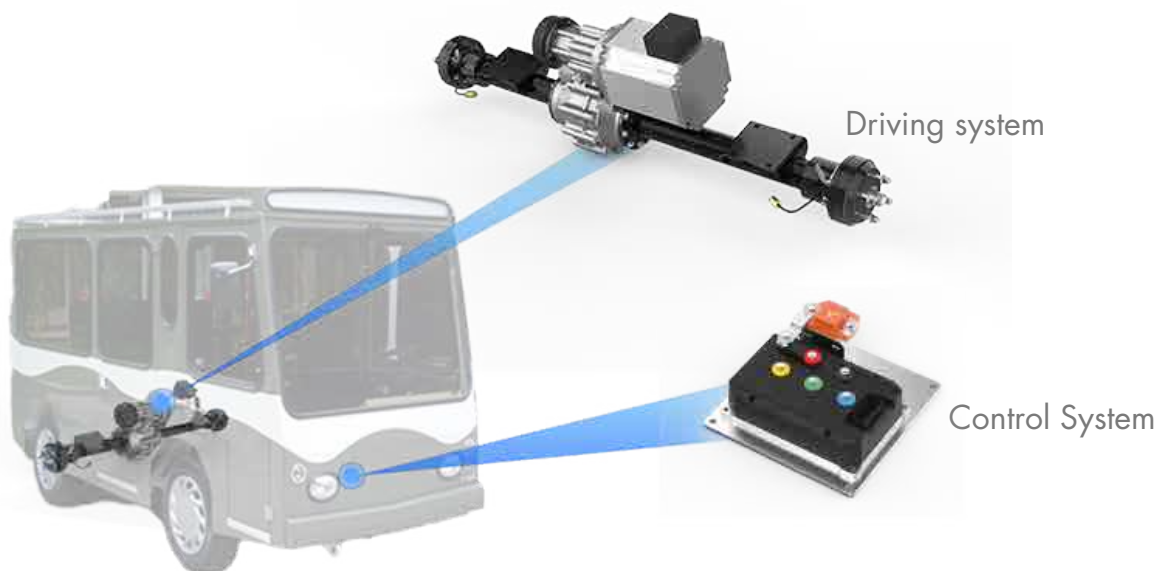

ZHONGSHAN ROTON INTELLIGENT TECHNOLOGY CO.,LTD

☎ +86-18022183568

✉ richh@rotontec.com

📍 19 Renqian Road, Sanxiang Town, Zhongshan City, Guangdong Province, China